

# 2 Mega Pixel Macro Lens

## ML-MCHR Series

High quality image and image format 12.8mm, the ML-MCHR Series is not only the best machine vision lens compatible with the latest 2 Mega pixel CMOS sensor, but also vibration resistance design is one of great benefit for industrial applications.

- Vibration resistance up to 5G <sup>(\*)1</sup>, 10G version option available
- Five models with magnification range from 0.05x to 1.72x <sup>(\*)2</sup>
- Close-up rings can be used to adjust magnification and working distance
- Distortion-free, high performance design
- Maximum compatible image format :  $\varnothing 12.8$



\*1 Vibration conditions:

- Frequency range: 10-200 [Hz]
- Test cycle: 8 minutes x10 sets against X, Y, and Z directions
- Maximum acceleration: 5G
- Maximum amplitude: 1 mm
- Lock screws used

\*2 Magnification using close-up rings

	Focal Distance	Magnification	O/I	WD	Fno	TV Distortion	Image Format	Weight
ML-MC16HR	16	x0.05~x0.2	363.9mm~118.7mm	317.5mm~69.8mm	2.5~16	-0.12% or less	$\varnothing 12.8$	43g
ML-MC25HR	25	x0.1~x0.4	309.6mm~126mm	255.9mm~64.6mm	2.7~16	0.05% or less	$\varnothing 12.8$	52g
ML-MC35HR	35	x0.25~x0.7	211.3mm~137.9mm	139.8mm~51mm	3.6~16	0.05% or less	$\varnothing 12.8$	73g
ML-MC50HR	50	x0.5~x0.8	228.4mm~205.5mm	149.1mm~111.1mm	3~16	0.07% or less	$\varnothing 12.8$	95g
ML-MC75HR	75	x0.18~x0.38	580.3mm~377.3mm	494.3mm~276.4mm	3.8~16	0.1% or less	$\varnothing 12.8$	105g

ML-MC16HR

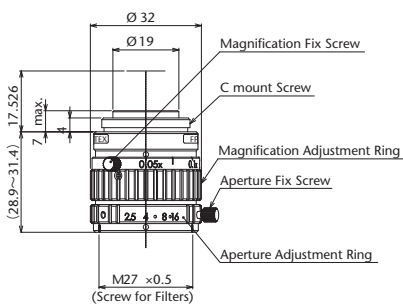

ML-MC25HR

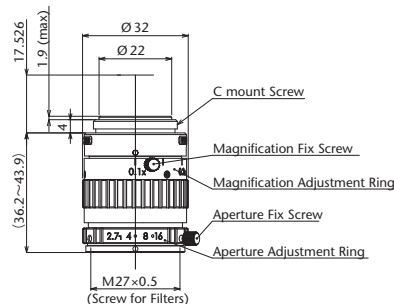

ML-MC35HR

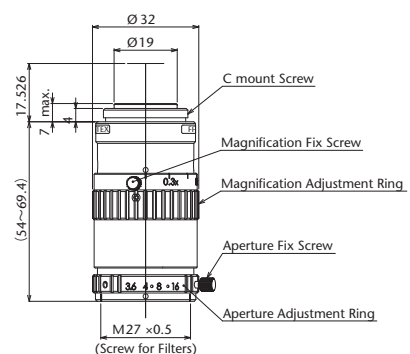

Field of View, WD and Magnification using Close-up Ring

Close-up Ring (mm)	ML-MC16HR				
	Field of View (Length x Width) 2/3"	Field of View (Length x Width) 1/2"	Field of View (Length x Width) 1/3"	WD (mm)	Magnification
0	33.0 X 44.0	24.0 X 32.0	18.0 X 24.0	71	X0.20
	132.0 X 176.0	96.0 X 128.0	72.0 X 96.0	318	X0.05

Close-up Ring (mm)	ML-MC25HR				
	Field of View (Length x Width) 2/3"	Field of View (Length x Width) 1/2"	Field of View (Length x Width) 1/3"	WD (mm)	Magnification
0	16.5 X 22.0	12.0 X 16.0	9.0 X 12.0	67	X0.40
	66.0 X 88.0	48.0 X 64.0	36.0 X 48.0	258	X0.10
0.5	15.7 X 21.0	11.4 X 15.3	8.6 X 11.4	64	X0.42
	55.2 X 73.6	40.1 X 53.5	30.1 X 40.1	216	X0.12
1	15.0 X 20.0	10.9 X 14.6	8.2 X 10.9	61	X0.44
	47.4 X 63.2	34.5 X 46.0	25.9 X 34.5	186	X0.14
1.5	14.4 X 19.2	10.5 X 13.9	7.8 X 10.5	59	X0.46
	41.6 X 55.4	30.2 X 40.3	22.7 X 30.2	164	X0.16
2	13.8 X 18.4	10.0 X 13.4	7.5 X 10.0	57	X0.48
	37.0 X 49.3	26.9 X 35.9	20.2 X 26.9	146	X0.18
5	11.1 X 14.8	8.1 X 10.7	6.0 X 8.1	46	X0.60
	22.3 X 29.7	16.2 X 21.6	12.2 X 16.2	89	X0.30
10	8.3 X 11.1	6.1 X 8.1	4.5 X 6.1	35	X0.79
	13.4 X 17.9	9.8 X 13.0	7.3 X 9.8	55	X0.49
15	6.7 X 8.9	4.9 X 6.5	3.6 X 4.9	29	X0.99
	9.6 X 12.8	7.0 X 9.3	5.2 X 7.0	40	X0.69
20	5.6 X 7.4	4.1 X 5.4	3.0 X 4.1	25	X1.18
	7.5 X 10.0	5.4 X 7.2	4.1 X 5.4	32	X0.88

Close-up Ring (mm)	ML-MC50HR				
	Field of View (Length x Width) 2/3"	Field of View (Length x Width) 1/2"	Field of View (Length x Width) 1/3"	WD (mm)	Magnification
0	8.2 X 11.0	6.0 X 8.0	4.5 X 6.0	111	X0.80
	13.2 X 17.6	9.6 X 12.8	7.2 X 9.6	149	X0.50
0.5	8.1 X 10.9	5.9 X 7.9	4.4 X 5.9	110	X0.81
	12.9 X 17.3	9.4 X 12.6	7.1 X 9.4	147	X0.51
1	8.1 X 10.7	5.9 X 7.8	4.4 X 5.9	110	X0.82
	12.7 X 16.9	9.2 X 12.3	6.9 X 9.2	145	X0.52
1.5	8.0 X 10.6	5.8 X 7.7	4.3 X 5.8	109	X0.83
	12.5 X 16.6	9.1 X 12.1	6.8 X 9.1	143	X0.53
2	7.9 X 10.5	5.7 X 7.6	4.3 X 5.7	108	X0.84
	12.2 X 16.3	8.9 X 11.9	6.7 X 8.9	142	X0.54
5	7.3 X 9.8	5.3 X 7.1	4.0 X 5.3	104	X0.90
	11.0 X 14.7	8.0 X 10.7	6.0 X 8.0	132	X0.60
10	6.6 X 8.8	4.8 X 6.4	3.6 X 4.8	99	X1.00
	9.5 X 12.6	6.9 X 9.2	5.2 X 6.9	120	X0.70
15	6.0 X 8.0	4.4 X 5.8	3.3 X 4.4	94	X1.10
	8.3 X 11.0	6.0 X 8.0	4.5 X 6.0	111	X0.80
20	5.5 X 7.4	4.0 X 5.4	3.0 X 4.0	90	X1.20
	7.4 X 9.8	5.4 X 7.1	4.0 X 5.4	104	X0.90
25	5.1 X 6.8	3.7 X 4.9	2.8 X 3.7	87	X1.29
	6.6 X 8.9	4.8 X 6.4	3.6 X 4.8	99	X0.99
30	4.7 X 6.3	3.4 X 4.6	2.6 X 3.4	84	X1.39
	6.0 X 8.0	4.4 X 5.9	3.3 X 4.4	94	X1.09
35	4.4 X 5.9	3.2 X 4.3	2.4 X 3.2	82	X1.49
	5.5 X 7.4	4.0 X 5.4	3.0 X 4.0	90	X1.19

Close-up Ring (mm)	ML-MC35HR				
	Field of View (Length x Width) 2/3"	Field of View (Length x Width) 1/2"	Field of View (Length x Width) 1/3"	WD (mm)	Magnification
0	9.4 X 12.6	6.9 X 9.1	5.1 X 6.9	54	X0.70
	26.4 X 35.2	19.2 X 25.6	14.4 X 19.2	143	X0.25
0.5	9.2 X 12.3	6.7 X 9.0	5.0 X 6.7	53	X0.71
	25.0 X 33.3	18.1 X 24.2	13.6 X 18.1	135	X0.26
1	9.1 X 12.1	6.6 X 8.8	4.9 X 6.6	52	X0.73
	23.7 X 31.5	17.2 X 22.9	12.9 X 17.2	128	X0.28
1.5	8.9 X 11.8	6.5 X 8.6	4.8 X 6.5	51	X0.74
	22.5 X 30.0	16.4 X 21.8	12.3 X 16.4	122	X0.29
2	8.7 X 11.6	6.3 X 8.4	4.7 X 6.3	50	X0.76
	21.4 X 28.6	15.6 X 20.8	11.7 X 15.6	117	X0.31
5	7.8 X 10.4	5.7 X 7.6	4.3 X 5.7	46	X0.84
	16.7 X 22.3	12.2 X 16.2	9.1 X 12.2	92	X0.39
10	6.7 X 8.9	4.8 X 6.5	3.6 X 4.8	40	X0.99
	12.2 X 16.3	8.9 X 11.9	6.7 X 8.9	69	X0.54
15	5.8 X 7.8	4.2 X 5.6	3.2 X 4.2	35	X1.13
	9.6 X 12.9	7.0 X 9.3	5.3 X 7.0	55	X0.68
20	5.2 X 6.9	3.8 X 5.0	2.8 X 3.8	32	X1.28
	8.0 X 10.6	5.8 X 7.7	4.3 X 5.8	46	X0.83

Close-up Ring (mm)	ML-MC75HR				
	Field of View (Length x Width) 2/3"	Field of View (Length x Width) 1/2"	Field of View (Length x Width) 1/3"	WD (mm)	Magnification
0	17.4 X 23.2	12.6 X 16.8	9.5 X 12.6	276	X0.38
	37.3 X 49.7	27.1 X 36.2	20.3 X 27.1	501	X0.18
0.5	17.1 X 22.8	12.4 X 16.5	9.3 X 12.4	273	X0.39
	35.9 X 47.9	26.1 X 34.8	19.6 X 26.1	486	X0.18
1	16.8 X 22.4	12.2 X 16.3	9.2 X 12.2	270	X0.39
	34.7 X 46.2	25.2 X 33.6	18.9 X 25.2	472	X0.19
1.5	16.5 X 22.0	12.0 X 16.0	9.0 X 12.0	267	X0.40
	33.5 X 44.6	24.3 X 32.5	18.3 X 24.3	458	X0.20
2	16.2 X 21.6	11.8 X 15.7	8.8 X 11.8	264	X0.41
	32.4 X 43.2	23.5 X 31.4	17.7 X 23.5	446	X0.20
5	14.8 X 19.7	10.7 X 14.3	8.1 X 10.7	247	X0.45
	27.0 X 36.0	19.7 X 26.2	14.7 X 19.7	386	X0.24
10	12.8 X 17.1	9.3 X 12.4	7.0 X 9.3	225	X0.51
	21.2 X 28.3	15.4 X 20.6	11.6 X 15.4	320	X0.31
15	11.4 X 15.1	8.3 X 11.0	6.2 X 8.3	209	X0.58
	17.4 X 23.3	12.7 X 16.9	9.5 X 12.7	277	X0.38
20	10.2 X 13.6	7.4 X 9.9	5.6 X 7.4	195	X0.65
	14.8 X 19.8	10.8 X 14.4	8.1 X 10.8	248	X0.45
25	9.2 X 12.3	6.7 X 8.9	5.0 X 6.7	184	X0.72
	12.9 X 17.2	9.4 X 12.5	7.0 X 9.4	226	X0.51
30	8.4 X 11.2	6.1 X 8.2	4.6 X 6.1	176	X0.78
	11.4 X 15.2	8.3 X 11.0	6.2 X 8.3	209	X0.58
35	7.8 X 10.4	5.6 X 7.5	4.2 X 5.6	168	X0.85
	10.2 X 13.6	7.4 X 9.9	5.6 X 7.4	196	X0.65
40	7.2 X 9.6	5.2 X 7.0	3.9 X 5.2	162	X0.92
	9.2 X 12.3	6.7 X 9.0	5.0 X 6.7	185	X0.71
45	6.7 X 8.9	4.9 X 6.5	3.7 X 4.9	156	X0.98
	8.5 X 11.3	6.1 X 8.2	4.6 X 6.1	176	X0.78
50	6.3 X 8.4	4.6 X 6.1	3.4 X 4.6	151	X1.05
	7.8 X 10.4	5.7 X 7.5	4.2 X 5.7	168	X0.85
60	5.6 X 7.4	4.0 X 5.4	3.0 X 4.0	143	X1.19
	6.7 X 9.0	4.9 X 6.5	3.7 X 4.9	156	X0.98
70	5.0 X 6.7	3.6 X 4.8	2.7 X 3.6	137	X1.32
	5.9 X 7.9	4.3 X 5.7	3.2 X 4.3	147	X1.12
80	4.5 X 6.1	3.3 X 4.4	2.5 X 3.3	132	X1.45
	5.3 X 7.0	3.8 X 5.1	2.9 X 3.8	140	X1.25
90	4.2 X 5.5	3.0 X 4.0	2.3 X 3.0	127	X1.59
	4.8 X 6.4	3.5 X 4.6	2.6 X 3.5	134	X1.39
100	3.8 X 5.1	2.8 X 3.7	2.1 X 2.8	124	X1.72
	4.3 X 5.8	3.2 X 4.2	2.4 X 3.2	129	X1.52

ML-MC50HR

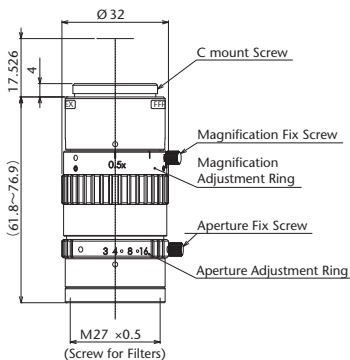

ML-MC75HR

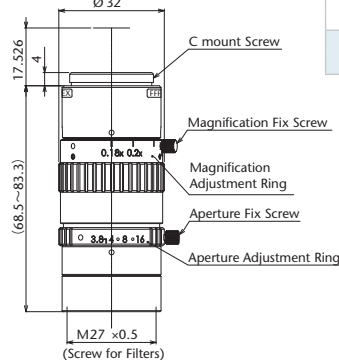

- Indicated values are based on calculation and actual measurements may differ. Please use values as a reference.
- Accuracy of the products is guaranteed only when used without additional attachments. Please note that when using in combination with a close-up ring or other equipment, working distance, distortion and image quality may be distorted due to enlargement of the lens tolerance.